

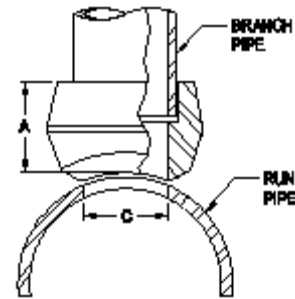

Socket Weld Outlets  
**Forged Steel**  
Inches / Pounds



Outlet Size (NPS)	Dimensions					
	Class 3000			Class 6000		
	A	C	Weight (lbs)	A	C	Weight (lbs)
1/8	3/4	0.269	0.07	1-1/8	0.157	0.15
1/4	3/4	0.364	0.12	1-1/8	0.250	0.30
3/8	13/16	0.493	0.16	1-1/8	0.359	0.30
1/2	1	0.622	0.27	1-1/4	0.464	0.48
3/4	1-1/16	0.824	0.36	1-7/16	0.612	0.81
1	1-5/16	1.049	0.59	1-9/16	0.815	1.30
1 1/4	1-5/16	1.380	0.84	1-5/8	1.160	1.54
1 1/2	1-3/8	1.610	1.00	1-11/16	1.338	1.97
2	1-1/2	2.067	1.53	2-1/16	1.687	5.01
2 1/2	1-13/16	2.469	2.66	2-11/16	2.125	6.19
3	2	3.068	3.72	2-11/16	2.624	7.36
3 1/2	2-1/8	3.548	4.40	-	-	-
4	2-1/4	4.026	7.05	3-5/16	3.438	14.02
5	2-5/8	5.047	9.46	3-11/16	4.313	20.03
6	2-11/16	6.065	14.03	4-1/8	5.187	29.36

*\* Dimensions conform to ASME B31.1 and MSS-SP-97.*