

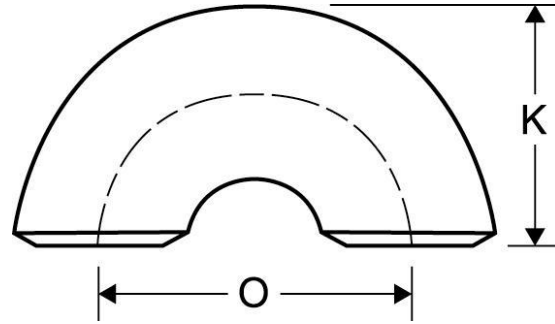

Short Radius 180° Return  
Bends

**SCHEDULE 160**

Inches / Pounds



Nominal Pipe Size	Outside Diameter	Inside Diameter	Wall Thickness	Center To Center (O)	Back To Face (K)	Approximate Weight (in Pounds)
1	1.32	0.815	0.250	2.00	1.62	–
1 ¼	1.66	1.160	0.250	2.50	2.06	–
1 ½	1.90	1.338	0.281	3.00	2.44	–
2	2.38	1.687	0.344	4.00	3.19	2.4
2 ½	2.88	2.125	0.375	5.00	3.94	–
3	3.50	2.624	0.438	6.00	4.75	5.6
4	4.50	3.438	0.531	8.00	6.25	–
5	5.56	4.313	0.625	10.00	7.75	–
6	6.63	5.187	0.719	12.00	9.31	–
8	8.63	6.813	0.906	16.00	12.31	–
10	10.75	8.500	1.125	20.00	15.38	–
12	12.75	10.126	1.312	24.00	18.38	–

*\* Dimensions conform to ASME B16.9 & material conforms to ASTM SA-234 Grade B.*