



## 2-PC. SCREWED END BRASS BALL VALVE

# SM600/SM615

### FEATURES



- MSS SP-110 Design
- 600 lb. CWP, 150 lb. WSP
- Full Port
- Forged Brass Body
- Chrome Plated Ball
- PTFE Seat & Seals
- Blow-out Proof Stem
- CSA Approved (1/2" thru 2") - Threaded
- ISO 9001:2008 Manufacturer
- UL Approved (1/2" thru 2") - Threaded
- Series 600 Standard Handle, Series 615 Lockable Handle



### Materials of Construction

Item	Part	Material Spec
1	Nut	Steel
2	Lock washer	Steel with Chrome or Zinc Alloy
3	Handle	
4	Gland Nut	ASTM B124
5	Stem	
6	Stem Packing	Teflon (PTFE)
7	Bonnet	ASTM B124
8	Seat Ring	Teflon (PTFE)
9	Ball	Chrome Plated Brass
10	Body	ASTM B124

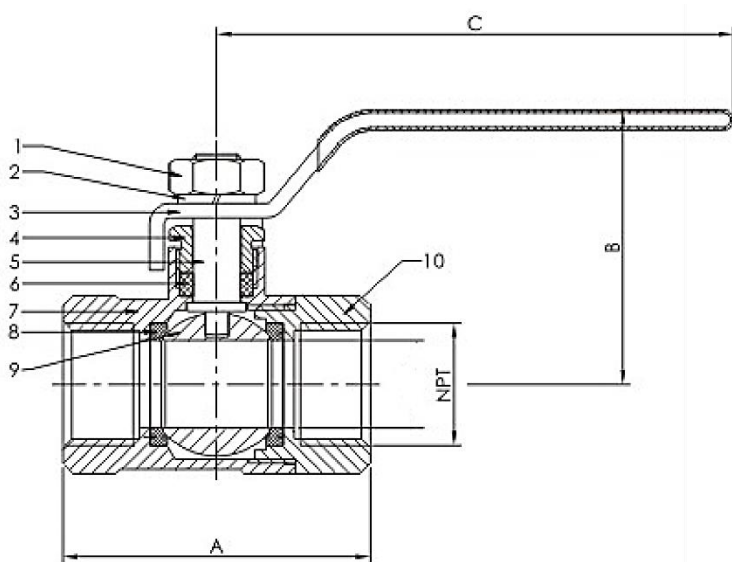

### Dimensions (Inches)

Size	A	B	C	Weight (lb)
1/4"	1.69	1.71	3.46	0.30
3/8"	1.69	1.71	3.46	0.30
1/2"	2.07	1.85	3.46	0.50
3/4"	2.38	2.13	4.33	0.70
1"	2.89	2.28	4.33	1.00
1-1/4"	3.27	2.80	5.51	1.70
1-1/2"	3.62	2.99	5.51	2.30
2"	4.41	3.27	5.51	3.50
2-1/2"	5.98	4.59	9.06	7.20
3"	6.50	4.86	9.06	8.80
4"	7.76	5.67	10.00	16.50

The information presented on this sheet is correct at the time of publication. Service Metal reserves the right to change design, and/or material specifications without notice.



**SERVICE METAL**  
Trust In Every Connection

St. Louis



Charlotte



Houston



servicemetal.net

800-325-7820