



3-PC. SCREWED END BALL VALVE

SM2300CT/SM3300ST

FEATURES

- Full Port 1/4" through 4"
- Working Pressure 1000 WOG
- Working Temperature -4° F through 392°F
- Blow-out Proof Stem
- Locking Device
- SM2300CT: A216-WCB • SM3300ST: A351-CF8M

SPECIFICATIONS

- Thread Ends Conform to ASME/ANSI B1.20.1 (NPT)
- API-598
- NACE MR-0175 STANDARD

Materials of Construction

| Item | Part | Material Spec | |
|------|---------------|-----------------|----------------|
| 1 | BODY | ASTM A216-WCB | ASTM A351-CF8M |
| 2 | CAP | | |
| 3 | BALL | ASTM A351-CF8M | |
| 4 | STEM | ASTM A276-316 | |
| 5 | SEAT | RTFE | |
| 6 | GASKET | PTFE | |
| 7 | PACKING | PTFE | |
| 8 | THRUST WASHER | PTFE | |
| 9 | GLANDNUT | AISI 304 | |
| 10 | SPRING WASHER | | |
| 11 | STEMNUT | | |
| 12 | BOLT | | |
| 13 | NUT | | |
| 14 | SPRING WASHER | | |
| 15 | HANDLE | Stainless Steel | |
| 16 | HANDLE SLEEVE | PVC | |
| 17 | LATCH LOCK | Stainless Steel | |

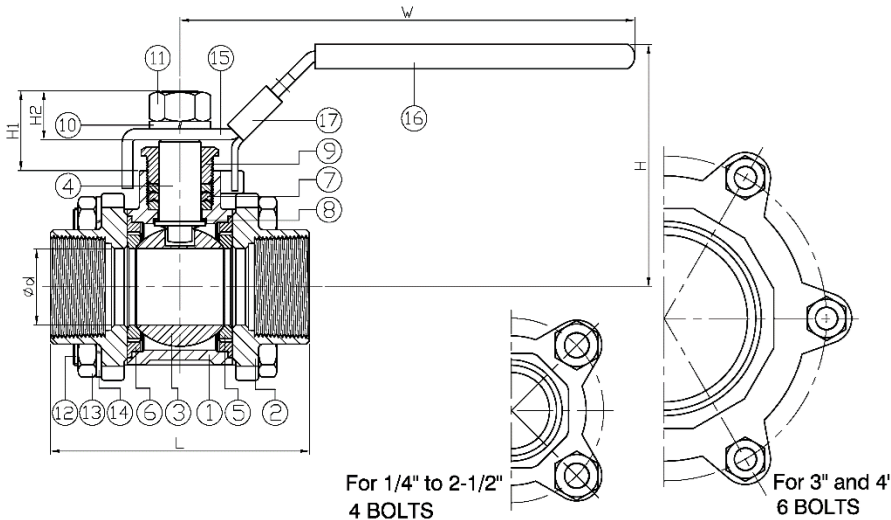
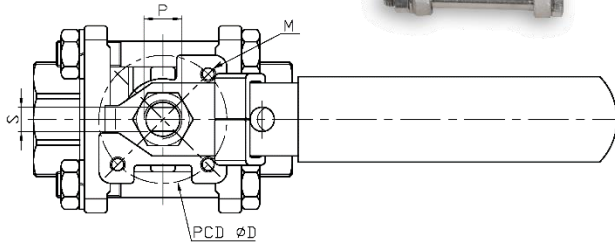

For 1/4" to 2-1/2"
4 BOLTS

For 3" and 4"
6 BOLTS

Dimensions (Inches)

| NPS | d | L | H | W | D | M | P | S | H1 | H2 | ISO | Torque (in-lb) | Weight (lb) |
|--------|------|------|------|-------|------|-----|-------------|------|------|------|-----|----------------|-------------|
| 1/4" | 0.46 | 2.56 | 2.26 | 4.07 | 1.42 | M5 | 3/8"-24UNF | 0.2 | 0.76 | 0.53 | F03 | 66.4 | 0.8 |
| 3/8" | 0.49 | 2.56 | 2.26 | 4.07 | 1.42 | M5 | 3/8"-24UNF | 0.2 | 0.76 | 0.53 | F03 | 66.4 | 0.8 |
| 1/2" | 0.59 | 2.56 | 2.42 | 4.07 | 1.42 | M5 | 3/8"-24UNF | 0.2 | 0.76 | 0.53 | F03 | 66.4 | 1.2 |
| 3/4" | 0.79 | 2.95 | 2.54 | 4.76 | 1.42 | M5 | 7/16"-20UNF | 0.26 | 0.92 | 0.63 | F03 | 66.4 | 1.6 |
| 1" | 0.98 | 3.35 | 3.15 | 5.79 | 1.65 | M5 | 7/16"-20UNF | 0.31 | 1.01 | 0.64 | F04 | 110.6 | 2.3 |
| 1-1/4" | 1.26 | 3.98 | 3.35 | 5.79 | 1.65 | M5 | 7/16"-20UNF | 0.31 | 1.01 | 0.64 | F04 | 132.8 | 3.6 |
| 1-1/2" | 1.5 | 4.41 | 4.08 | 7.4 | 1.97 | M6 | 1/2"-20UNF | 0.39 | 1.17 | 0.79 | F05 | 177 | 5.3 |
| 2" | 1.97 | 5.12 | 4.36 | 7.4 | 1.97 | M6 | 1/2"-20UNF | 0.39 | 1.17 | 0.79 | F05 | 221.3 | 7.9 |
| 2-1/2" | 2.48 | 6.38 | 5.4 | 9.84 | 2.76 | M8 | 3/4"-10UNC | 0.47 | 1.55 | 1.08 | F07 | 566.4 | 14.8 |
| 3" | 2.99 | 7.4 | 5.74 | 9.84 | 2.76 | M8 | 3/4"-10UNC | 0.47 | 1.55 | 1.08 | F07 | 752.3 | 21.6 |
| 4" | 3.78 | 8.82 | 7.15 | 12.52 | 4.02 | M10 | 1"-8UNC | 0.63 | 2.11 | 1.57 | F10 | 840.8 | 42.3 |

The information presented on this sheet is correct at the time of publication. Service Metal reserves the right to change design, and/or material specifications without notice.

PRESSURE-TEMPERATURE RATING

