

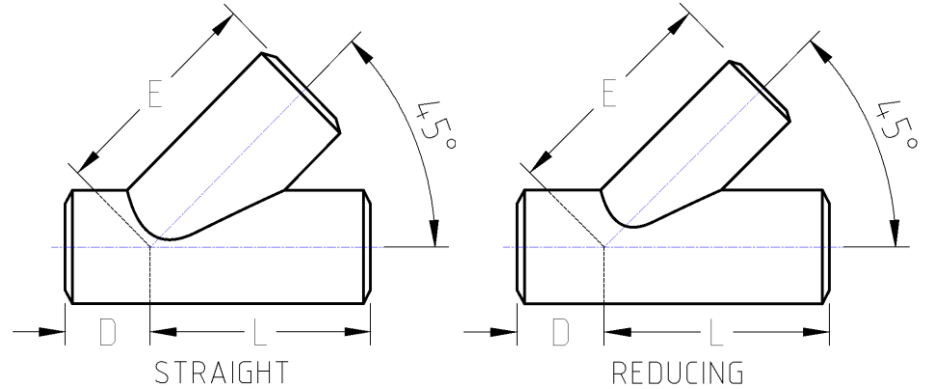

Welding Laterals
**STANDARD WEIGHT
AND EXTRA STRONG**
Inches / Pounds



Nominal Pipe Size	Dimensions			Approximate Weight (in Pounds)	
	D	L	E	Standard Wall	Extra Strong
1	1.75	3.50	3.50	1.7	2.5
1 ¼	2.00	4.25	4.25	2.4	3.8
1 ½	2.50	5.00	5.00	3.3	5.5
2	3.25	6.00	6.00	5.0	7.7
2 ½	3.50	7.00	7.00	9.0	13
3	3.75	7.75	7.75	12.5	18
3 ½	4.00	8.38	8.38	17.2	25
4	4.50	8.50	8.50	20.5	32
5	4.75	11.00	11.00	31	49
6	5.25	12.50	12.50	42	78
8	6.25	15.25	15.25	76	140
10	7.00	18.00	18.00	124	300
12	8.00	21.50	21.50	180	273
14	10.00	25.00	25.00	218	340
16	12.00	28.50	28.50	275	431
18	13.00	32.00	32.00	326	525
20	14.00	35.00	35.00	396	625
24	16.25	41.25	41.25	544	875

*** The working pressure of any fabricated lateral must be rated at only 40% of the allowable working pressure established for the pipe from which the lateral is being made.**