

Class 300 • Outside Screw & Yoke • Bolted Bonnet

Material of Construction

Description	Material
Body	WCB
Bonnet	WCB
Seat Rings	Hardfaced
Disc	13% CR Overlay
Stem	410 SS
Packing	Graphite
Bonnet Gasket	Spiral Wound
Back Seat	410 SS
Disc Stem Nut	410 SS
Disc Washer	Carbon Steel
Gland	410 SS
Gland Flange	WCB
Eye Bolt	Steel
Eye Bolt Nuts	A563 Gr. A or O
Pins	-
Bonnet Studs	A193 Gr. B7
Bonnet Nuts	A194 Gr. 2H
Handwheel	WCB
Handwheel Nut	A194 Gr. 2H
I.D. Tags	SS
I.D. Pins	SS

Figure 151
Flanged
Figure 151^{1/2}
Butt Weld

Size Range:
2 through 12 inches

Pressure Temperature Rating
Carbon Steel
ASTM A216 Grade WCB
740 psi @ -20°F to 100°F

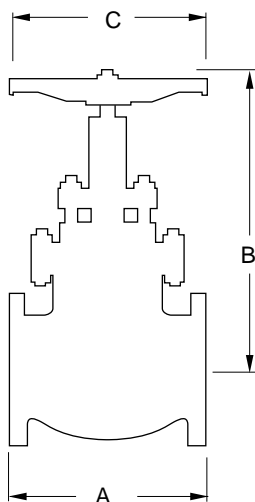
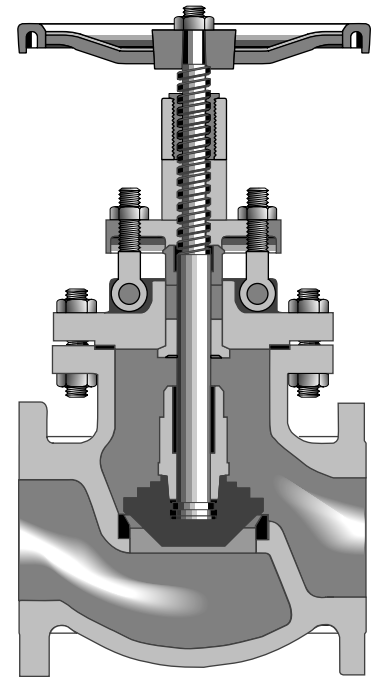

Industry Standards

Steel Valves	ANSI B16.34
Face-to-Face/End-to-End	ANSI B16.10
Flange Dimensions	ANSI B16.5
Weld End	ANSI B16.25
Testing	API 598
Acceptance	API RP591

Dimensions and Weights

Valve Size	Weight (pounds)		Dimensions (inches)		
			A	B Valve Open	C
2	75	48	10.50	16.75	8.00
2 ^{1/2}	99	73	11.50	19.00	10.00
3	132	97	12.50	21.00	10.00
4	209	140	14.00	24.00	14.00
5	290	240	15.75	27.50	14.00
6	440	280	17.50	31.00	18.00
8	693	460	22.00	34.25	24.00
10	1008	620	24.50	37.00	24.00
12	1100	900	28.00	50.00	24.00