



Class 150 • Rising Stem • Threaded Ends

Figure 14¹/₂ P

Size Range:

1/4" through 3"

Working Pressures Non-Shock:

150 psi Steam, Basic Rating

300 psi Cold Working Pressure

Features

- Union Bonnet, 1/2"-2"
- Threaded Ends
- Bolted Bonnet, 2 1/2" and 3"
- Back Seat
- Stainless Steel Seat Ring
- MSS-SP-80, Type 3

For more detailed features, refer to page 34.

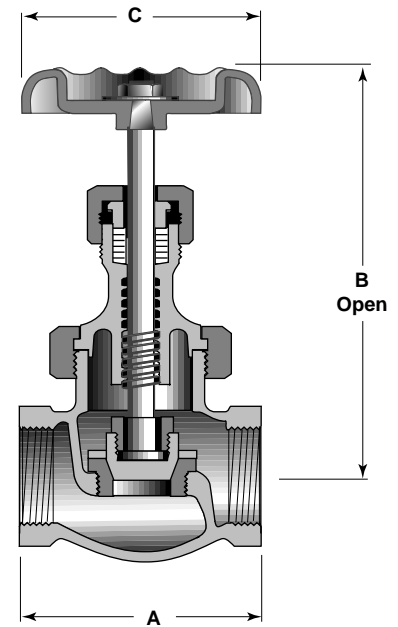

Principal Parts & Materials

Part	Sizes	Material	ASTM
Body	All	Bronze	B62 alloy C83600
Bonnet	1/4"-3/8"	Brass	B16 H02
Bonnet	1/2"-3"	Bronze	B62 alloy C83600
Disc and seat ring	All	Stainless Steel	A276 S42000
Stem	All	Bronze	B371 alloy C69400

Dimensions and Weights

Inches (millimeters) - pounds (kilograms)

	1/4 (6)	3/8 (10)	1/2 (15)	3/4 (20)	1 (25)	1 1/4 (32)	1 1/2 (40)	2 (50)	2 1/2 (65)	3 (80)
A	1.97 (50)	1.97 (50)	2.63 (67)	2.99 (76)	3.51 (89)	4.04 (103)	4.57 (116)	5.72 (145)	7.28 (185)	8.70 (221)
B	4.43 (113)	4.43 (113)	4.09 (104)	5.10 (130)	5.58 (142)	6.42 (163)	7.17 (182)	7.48 (190)	8.44 (214)	9.79 (249)
C	2.13 (54)	2.13 (54)	2.25 (57)	2.98 (76)	3.02 (77)	3.68 (93)	4.63 (118)	5.24 (133)	6.97 (177)	7.00 (178)
WTS.	0.90 (0.39)	0.90 (0.39)	1.30 (0.59)	2.20 (1.00)	3.20 (1.45)	4.80 (2.18)	7.10 (3.22)	11.50 (5.20)	25.10 (11.37)	40.50 (18.38)