

Class 600 • Outside Screw & Yoke • Flexible Wedge Disc

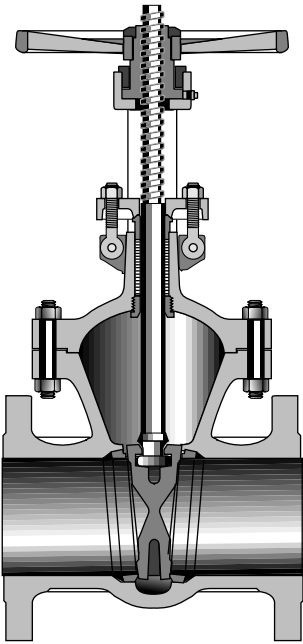

Figure 76
Flanged
Figure 76^{1/2}
Butt Weld

Size Range:
2 through 12 inches

Pressure Temperature Rating
Carbon Steel
ASTM A216 Grade WCB
1480 psi @ -20°F to 100°F

Material of Construction

Description	Material
Body	WCB
Bonnet	WCB
Seat Rings	Hardfaced
Disc	CA-15 or 13% CR Overlay
Stem	410 SS
Packing	Graphite
Bonnet Gasket	Ring Joint
Back Seat	410 SS
Yoke Sleeve	D2 Ni-Resist
Retaining Nut	Malleable or Steel
Gland	Steel
Gland Flange	Steel
Eye Bolt	Steel
Eye Bolt Nuts	Steel
Pins	Steel
Bonnet Studs	A193 Gr. B7
Bonnet Nuts	A194 Gr. 2H
Handwheel	Malleable, Ductile, or Steel
Handwheel Nut	Ductile or Steel
I.D. Tags	SS
I.D. Pins	Steel
Spacer	Steel
Grease Fittings	Steel

Industry Standards

Steel Valves	ANSI B16.34
Face-to-Face/End-to-End	ANSI B16.10
Flange Dimensions	ANSI B16.5
Weld End	ANSI B16.25
Basic Design	API 600
Testing	API 598
Acceptance	API RP591

Dimensions and Weights

Valve Size	Weight (pounds)		Dimensions (inches)		
			A	B	C
	76	76 ^{1/2}	76 & 76 ^{1/2}	Valve Open	
2	84	72	11.50	18.00	10.00
2 ^{1/2}	130	112	13.00	20.50	10.00
3	160	140	14.00	22.00	12.00
4	300	270	17.00	26.50	14.00
6	640	520	22.00	36.00	18.00
8	1080	940	26.00	39.50	20.00
10	1550	1250	31.00	47.00	25.00
12	2100	1800	33.00	57.50	28.00

