

Class 125 • Non-Rising Stem

Features

- Tapered Solid Wedge Disc
- Body Guide Ribs
- Renewable Bronze Seat Rings
- Stem provided with ACME Double Threads for valves 24" and smaller; ACME Single Thread for 30" valves.
- Non-Asbestos Packing and Gaskets
- MSS-SP-70 Type 1 and MSS-SP-25
- ANSI/ASME B16.10, ANSI/ASME B16.1,
- Valves can be equipped with by-passes when specified.

For more detailed features, refer to page 6.

Figure 461

Flanged with Bronze Trim

Size Range:

2 through 30 inches

Working Pressures Non-Shock

- 2" – 12"
 - 125 psi Steam, Basic Rating
 - 200 psi Cold Working Pressure
- 14" – 24"
 - 100 psi Steam, Basic Rating
 - 150 psi Cold Working Pressure
- 30"
 - 50 psi Steam, Basic Rating
 - 150 psi Cold Working Pressure

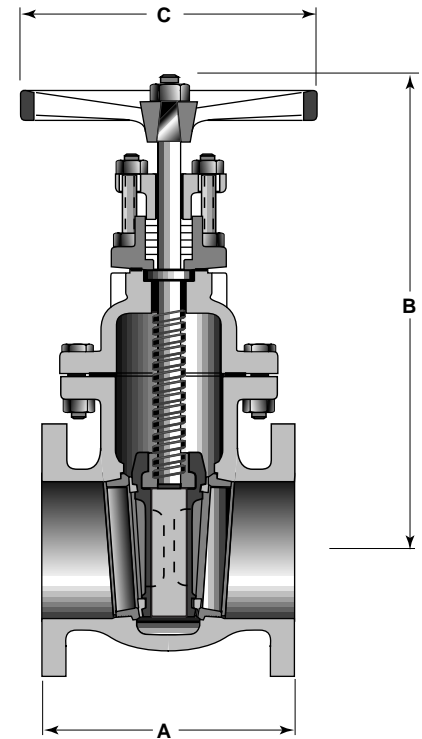

Principal Parts & Materials

Fig. No.	Size	Stem	Seating	End Conn.
461	2" - 30"	Bronze	Bronze	Flanged

Dimensions and Weights

Inches (millimeters) - pounds (kilograms)

Valves	2 (50)	2 1/2 (65)	3 (80)	4 (100)	5 (125)	6 (150)	8 (200)	10 (250)	12 (300)	14 (350)	16 (400)	18 (450)	20 (500)	24 (600)	30 (750)
A	7.00 (178)	7.50 (191)	8.00 (203)	9.00 (229)	10.00 (254)	10.50 (267)	11.50 (292)	13.00 (330)	14.00 (356)	15.00 (381)	16.00 (406)	17.00 (432)	18.00 (457)	20.00 (508)	24.00 (610)
B	11.31 (287)	12.40 (315)	13.25 (337)	16.31 (414)	18.00 (457)	20.69 (526)	24.12 (613)	33.00 (838)	36.50 (927)	40.50 (1029)	46.62 (1184)	50.75 (1289)	56.12 (1425)	64.00 (1625)	86.63 (2200)
C	8.00 (203)	8.00 (203)	8.00 (203)	10.00 (254)	10.00 (254)	12.00 (305)	14.00 (356)	20.00 (508)	20.00 (508)	20.00 (508)	22.00 (559)	22.00 (559)	24.00 (610)	30.00 (762)	30.00 (762)
Wt.	30 (13.6)	40 (18.1)	56 (25.4)	90 (41.0)	126 (57.2)	152 (69.0)	260 (118)	475 (215)	680 (308)	968 (439)	1350 (613)	1701 (772)	2188 (994)	3150 (1430)	6009 (2728)