



Class 150 • Non Rising Stem • Threaded Ends

Figure 437

Size Range:

1/4" through 3"

Working Pressures Non-Shock:

150 psi Steam, Basic Rating

300 psi Cold Working Pressure

Features

- Non-Rising Stem
- Screwed Bonnet
- Solid Wedge Disc
- Threaded Ends
- Full Ports
- Back Seat
- Integral Bronze Seat
- MSS-SP-80, Type 1

For more detailed features, refer to page 18.

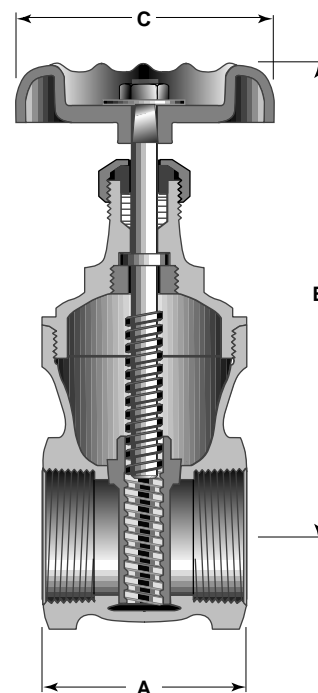

Principal Parts & Materials

Part	Size	Material	ASTM
Body & bonnet	All	Bronze	B62 alloy C83600
Disc	All	Bronze	B62 alloy C83600
Stem	1/2"-2"	Bronze	B505 alloy C83600
Stem	1/4"-3/8", 2 1/2"-3"	Bronze	B371 alloy C69400

Dimensions and Weights

Inches (millimeters) - pounds (kilograms)

	1/4 (6)	3/8 (10)	1/2 (15)	3/4 (20)	1 (25)	1 1/4 (32)	1 1/2 (40)	2 (50)	2 1/2 (65)	3 (80)
A	1.64 (42)	1.65 (42)	2.02 (51)	2.14 (54)	2.46 (63)	2.77 (70)	2.85 (72)	3.24 (82)	4.20 (107)	4.65 (118)
B	3.65 (98)	3.70 (94)	3.23 (82)	4.18 (106)	4.73 (120)	5.62 (143)	6.53 (166)	7.35 (187)	9.20 (234)	10.13 (257)
C	2.06 (52)	2.06 (52)	2.06 (52)	2.56 (65)	2.75 (70)	3.08 (78)	3.62 (92)	4.00 (102)	5.22 (133)	5.22 (133)
WTS.	0.80 (0.34)	0.80 (0.34)	0.80 (0.32)	1.30 (0.56)	1.80 (0.79)	3.00 (1.34)	3.70 (1.66)	5.70 (2.59)	12.40 (5.60)	17.70 (8.00)