

### Class 125 • Y-Pattern • Threaded Ends

#### Features

- Recommended for non-shock water, oil or gas.
- Threaded Ends
- Screwed Cap
- Y-Pattern Body
- PTFE Disc
- Always install with pressure under the disc in vertical or horizontal position. An arrow cast on the body indicates the correct direction of flow.
- MSS Specification SP-80

For more detailed features, refer to page 46.

#### Figure 41TF

##### Size Range:

1/2" through 2"

##### Working Pressures Non-Shock:

125 psi Steam, Basic Rating

200 psi Cold Working Pressure

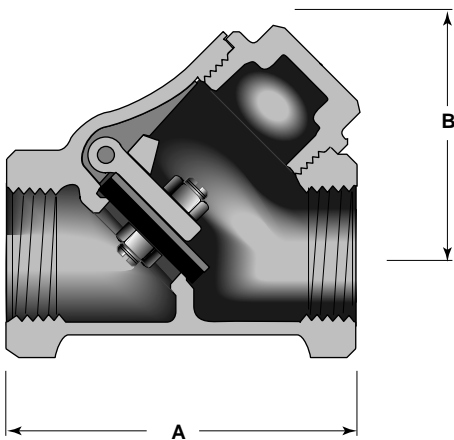

#### Principal Parts & Materials

Part	Sizes	Material	ASTM
Body	All	Bronze	B62 alloy C83600
Cap	All	Bronze	B61 alloy C92200
Disc	All	PTFE w/metal holder	
Hinge	All	Bronze	B584 alloy 87600
Hinge pin	All	Stainless Steel	18-8

#### Dimensions and Weights

Inches (millimeters) - pounds (kilograms)

	1/2 (15)	3/4 (20)	1 (25)	1 1/4 (32)	1 1/2 (40)	2 (50)
A	2.19 (56)	2.75 (70)	3.23 (82)	3.84 (98)	4.40 (112)	5.18 (132)
B	1.64 (42)	1.92 (49)	2.45 (62)	2.86 (73)	3.42 (87)	4.13 (105)
WTS.	0.70 (0.32)	1.10 (0.50)	1.80 (0.82)	2.60 (1.18)	3.90 (1.77)	6.20 (2.81)