

Class 300 • Bolted Cap

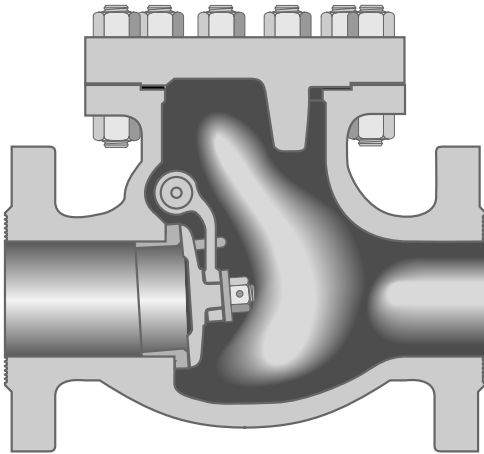

Figure 159
Flanged
Figure 159^{1/2}
Butt Weld

Size Range:
2 through 24 inches

Pressure Temperature Rating
Carbon Steel
ASTM A216 Grade WCB
740 psi @ -20°F to 100°F

Material of Construction

| Description | Material |
|-------------|----------------|
| Body | WCB |
| Cap | WCB |
| Seat Ring | Hardfaced |
| Disc | 13% CR Overlay |
| Hinge | WCB |
| Pins, Hinge | 410 SS |
| Disc Washer | Steel |
| Cap Screw | A307 Gr. B |
| Cap Gasket | Spiral Wound |
| Cap Studs | A193 Gr. B7 |
| Cap Nuts | A194 Gr. 2H |
| I.D. Tags | SS |
| I.D. Pins | Steel |

Industry Standards

| | |
|-------------------------|-------------|
| Steel Valves | ANSI B16.34 |
| Face-to-Face/End-to-End | ANSI B16.10 |
| Flange Dimensions | ANSI B16.5 |
| Weld End | ANSI B16.25 |
| Testing | API 598 |
| Acceptance | API RP591 |

Dimensions and Weights

| Valve Size | Weight (pounds) | | Dimensions (inches) | |
|------------------|-----------------|--------------------|--------------------------|-------|
| | | | A | B |
| | 159 | 159 ^{1/2} | 159 & 159 ^{1/2} | |
| 2 | 46 | 33 | 10.50 | 6.75 |
| 2 ^{1/2} | 66 | 49 | 11.50 | 7.38 |
| 3 | 86 | 66 | 12.50 | 8.50 |
| 4 | 154 | 97 | 14.00 | 9.25 |
| 5 | 255 | 203 | 15.75 | 10.62 |
| 6 | 276 | 216 | 17.50 | 11.88 |
| 8 | 420 | 330 | 21.00 | 13.38 |
| 10 | 640 | 500 | 24.50 | 13.88 |
| 12 | 1000 | 830 | 28.00 | 16.62 |
| 14 | 1550 | 1100 | 33.00 | 18.88 |
| 16 | 1700 | 1400 | 34.00 | 20.50 |
| 18 | 2200 | 1900 | 38.50 | 23.62 |
| 20 | 2800 | 2425 | 40.00 | 26.38 |
| 24 | 3650 | 3100 | 53.00 | 29.62 |

