

Class 150 • Bolted Cap

Material of Construction

Description	Material
Body	WCB
Cap	WCB
Seat Ring	Hardfaced
Disc	13% CR Overlay
Hinge	WCB
Pins, Hinge	410 SS
Disc Washer	Steel
Cap Screw	A307 Gr. B
Cap Gasket	Soft Iron
Cap Studs	A193 Gr. B7
Cap Nuts	A194 Gr. 2H
I.D. Tags	SS
I.D. Pins	Steel

Figure 147

Flanged
Figure 147½
Butt Weld

Size Range:
2 through 24 inches

Pressure Temperature Rating
Carbon Steel
ASTM A216 Grade WCB
285 psi @ -20°F to 100°F

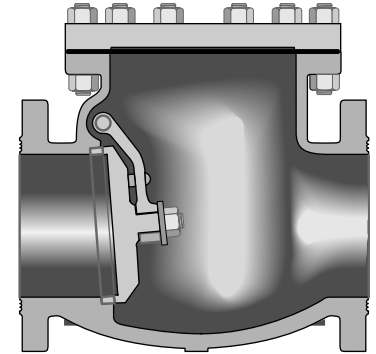

Industry Standards

Steel Valves	ANSI B16.34
Face-to-Face/End-to-End	ANSI B16.10
Flange Dimensions	ANSI B16.5
Weld End	ANSI B16.25
Testing	API 598
Acceptance	API RP591

Dimensions and Weights

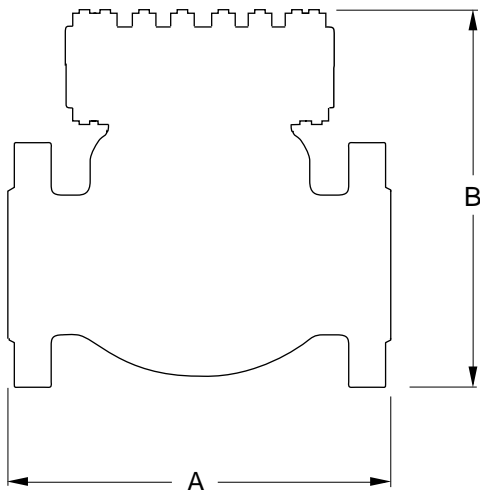

Valve Size	Weight (pounds)		Dimensions (inches)	
	147	147½	A	B
2	33	26	8.00	6.75
2½	57	37	8.50	7.12
3	59	40	9.50	7.38
4	93	71	11.50	8.50
5	152	126	13.00	9.50
6	165	132	14.00	10.25
8	275	235	19.50	11.88
10	440	385	24.50	13.88
12	680	570	27.50	15.75
14	950	810	31.00	17.75
16	1225	1065	34.00	19.00
18	1700	1500	38.50	21.25
20	1850	1600	38.50	23.58
24	2900	2550	51.00	26.75