

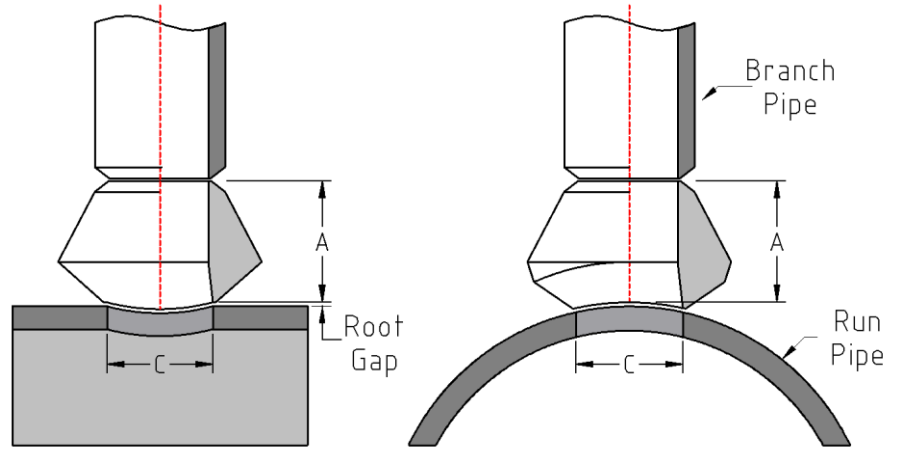

Butt Weld Outlets
Forged Steel
Inches / Pounds



Dimensions

Outlet Size (NPS)	Dimensions									
	Standard			Extra Heavy			S160	XXH		
	A	C	Weight	A	C	Weight	A	C	C	Weight
1/8	5/8	0.269	0.08	5/8	0.215	0.10				
1/4	5/8	0.364	0.08	5/8	0.302	0.08				
3/8	3/4	0.493	0.15	3/4	0.423	0.15				
1/2	3/4	0.622	0.18	3/4	0.546	0.20	1-1/8	0.466	0.252	0.23
3/4	7/8	0.804	0.25	7/8	0.722	0.31	1-1/4	0.614	0.434	0.65
1	1-1/16	1.049	0.50	1-1/16	0.957	0.55	1-1/2	0.815	0.599	0.78
1 1/4	1-1/4	1.380	0.80	1-1/4	1.278	0.90	1-3/4	1.160	0.896	1.16
1 1/2	1-5/16	1.610	1.00	1-5/16	1.500	1.10	2	1.338	1.100	1.60
2	1-1/2	2.067	1.75	1-1/2	1.939	1.75	2-3/16	1.689	1.503	1.95
2 1/2	1-5/8	2.469	2.50	1-5/8	2.323	2.28	2-7/16	2.125	1.771	3.02
3	1-3/4	3.068	3.82	1-3/4	2.900	3.50	2-7/8	2.624	2.300	5.75
3 1/2	1-7/8	3.548	5.10	1-7/8	3.364	4.75				
4	2	4.026	6.20	2	3.826	5.00	3-7/16	3.438	3.152	9.56
5	2-1/4	5.047	8.00	2-1/4	4.813	8.50	3-11/16	4.313	4.063	12.65
6	2-3/8	6.065	11.50	3-1/16	5.761	15.00	4-1/8	5.189	4.897	25.25
8	2-3/4	7.981	22.00	3-7/8	7.625	35.00				
10	3-1/16	10.020	37.00	3-11/16	9.750	46.00				
12	3-3/8	12.000	44.00	4-1/16	11.750	63.00				
14	3-1/2	13.250	63.00	3-15/16	13.000	72.00				
16	3-11/16	15.250	76.00	4-3/16	15.000	102.00				
18	3-13/16	17.250	100.00	4-3/8	17.000	130.00				
20	4	19.250	112.00	4-11/16	19.000	163.00				
24	4-9/16	23.250	210.00	5-1/2	23.000	271.00				

* Dimensions conform to ASME B31.1 and MSS-SP-97.