



Threaded Reducing Coupling

Std Pattern

150# Cast Stainless Steel

Inches / Pounds

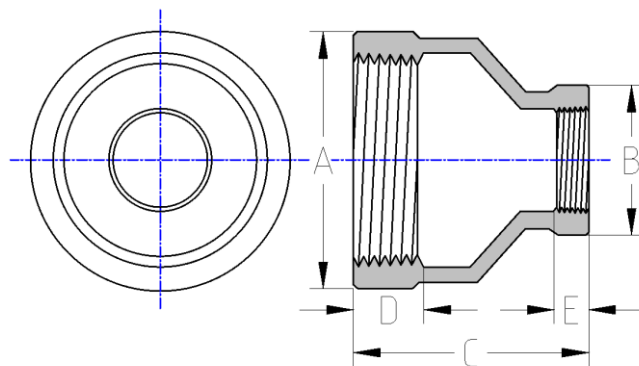

Nominal Pipe Size	Outside Diameter (A)	Outside Diameter (B)	End to End (C)	Internal Thread Length (D)	Internal Thread Length (E)	Approx. Weight (in Pounds)
1/4" X 1/8"	0.79	0.61	1.10	0.34	0.30	0.06
3/8" X 1/8"	0.98	0.61	1.61	0.41	0.35	0.13
3/8" X 1/4"	0.98	0.78	1.61	0.51	0.41	0.15
1/2" X 1/8"	1.18	0.61	1.73	0.39	0.30	0.16
1/2" X 1/4"	1.18	0.79	1.73	0.41	0.47	0.18
1/2" X 3/8"	1.18	1.00	1.75	0.41	0.47	0.20
3/4" X 1/8"	1.42	0.60	1.77	0.41	0.35	0.16
3/4" X 1/4"	1.42	0.78	1.77	0.35	0.37	0.21
3/4" X 3/8"	1.42	0.97	1.75	0.36	0.37	0.23
3/4" X 1/2"	1.38	1.16	1.76	0.33	0.49	0.27
1" X 1/8"	1.77	0.61	1.97	0.51	0.33	0.35
1" X 1/4"	1.76	0.78	1.95	0.55	0.45	0.36
1" X 3/8"	1.77	1.00	1.97	0.51	0.49	0.38
1" X 1/2"	1.77	1.18	1.97	0.49	0.51	0.41
1" X 3/4"	1.76	1.40	1.97	0.55	0.55	0.42
1-1/4" X 1/8"	2.09	0.61	1.99	0.65	0.39	0.48
1-1/4" X 1/4"	2.07	0.79	1.98	0.61	0.61	0.48
1-1/4" X 3/8"	2.07	0.98	1.95	0.64	0.55	0.48
1-1/4" X 1/2"	2.06	1.18	1.93	0.61	0.57	0.52
1-1/4" X 3/4"	2.06	1.40	1.93	0.65	0.63	0.53
1-1/4" X 1"	2.07	1.75	1.94	0.65	0.79	0.62

****The material composition and quality comply with ASTM A351/A351M "Standard Specification for Castings, Austenitic, for Pressure-Containing Parts"***

****NPT Threads on all fittings conform to ASME B1.20.1***



Threaded Reducing Coupling Std
Pattern

150# Cast Stainless Steel

Inches / Pounds

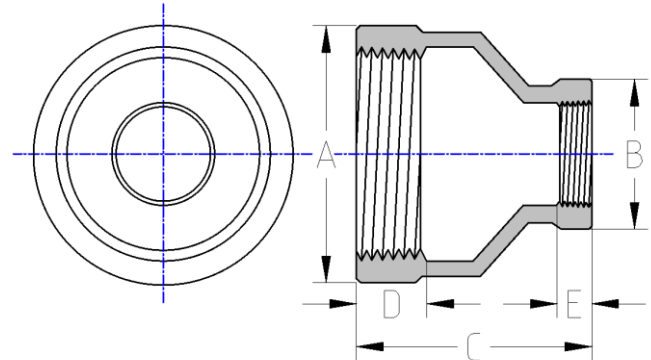

Nominal Pipe Size	Outside Diameter (A)	Outside Diameter (B)	End to End (C)	Internal Thread Length (D)	Internal Thread Length (E)	Approx. Weight (in Pounds)
1-1/2" X 1/4"	2.35	0.79	2.24	0.67	0.45	0.61
1-1/2" X 3/8"	2.35	0.98	2.24	0.69	0.55	0.61
1-1/2" X 1/2"	2.36	1.18	2.24	0.71	0.57	0.61
1-1/2" X 3/4"	2.36	1.42	2.24	0.69	0.57	0.66
1-1/2" X 1"	2.34	1.74	2.24	0.71	0.63	0.70
1-1/2" X 1-1/4"	2.36	2.09	2.24	0.67	0.62	0.75
2" X 3/8"	2.89	0.98	2.60	0.73	0.51	1.01
2" X 1/2"	2.89	1.18	2.60	0.77	0.58	1.01
2" X 3/4"	2.85	1.39	2.59	0.77	0.59	1.03
2" X 1"	2.88	1.73	2.60	0.71	0.69	1.08
2" X 1-1/4"	2.87	2.09	2.60	0.70	0.62	1.12
2" X 1-1/2"	2.87	2.36	2.58	0.73	0.63	1.17
2-1/2" X 1/2"	3.52	1.18	2.95	0.89	0.67	1.65
2-1/2" X 3/4"	3.50	1.44	2.97	0.90	0.70	1.65
2-1/2" X 1"	3.50	1.76	2.95	0.90	0.70	1.65
2-1/2" X 1-1/4"	3.50	2.07	2.95	1.00	0.79	1.73
2-1/2" X 1-1/2"	3.52	2.36	2.95	1.02	0.91	1.78
2-1/2" X 2"	3.52	2.87	2.90	0.89	0.97	1.93

****The material composition and quality comply with ASTM A351/A351M "Standard Specification for Castings, Austenitic, for Pressure-Containing Parts"***

****NPT Threads on all fittings conform to ASME B1.20.1***



Threaded Reducing Coupling
Std Pattern

150# Cast Stainless Steel

Inches / Pounds

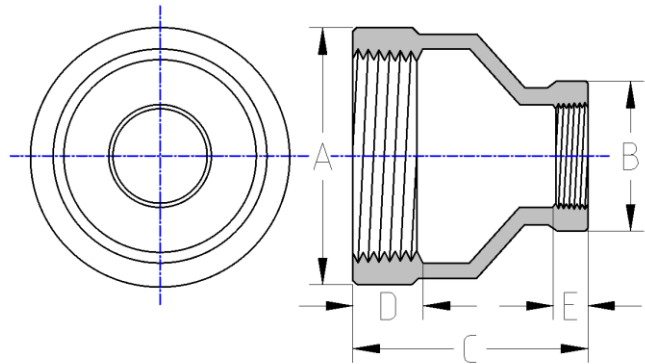

Nominal Pipe Size	Outside Diameter (A)	Outside Diameter (B)	End to End (C)	Internal Thread Length (D)	Internal Thread Length (E)	Approx. Weight (in Pounds)
3" X 1"	4.27	1.77	3.30	1.08	0.80	2.7
3" X 1-1/4"	4.27	2.09	3.25	1.10	0.93	2.2
3" X 1-1/2"	4.27	2.35	3.25	1.10	0.94	2.8
3" X 2"	4.27	2.92	3.11	1.22	0.90	2.8
3" X 2-1/2"	4.30	3.53	3.67	1.04	1.06	3.1
4" X 1-1/4"	5.39	2.09	3.76	1.10	0.81	5.0
4" X 1-1/2"	5.41	2.37	3.76	1.15	1.05	5.0
4" X 2"	5.41	2.89	3.80	1.13	1.06	5.0
4" X 2-1/2"	5.41	3.53	3.74	1.14	1.13	5.1
4" X 3"	5.37	4.28	3.81	1.22	1.36	5.6

****The material composition and quality comply with ASTM A351/A351M "Standard Specification for Castings, Austenitic, for Pressure-Containing Parts"***

****NPT Threads on all fittings conform to ASME B1.20.1***