



# 125# CI OS&Y FLANGED GATE VALVE

# SM125GVO



## FEATURES

- Class 125
- Flanged Ends
- 200 WOG/125 SWP
- OS&Y
- Bolted Bonnet
- Rising Stem
- Solid Wedge
- IBBM

## APPLICABLE STANDARDS

- Face to Face Dimension Conforms to ANSI B16.10
- Flanged Ends Conforms to ANSI B16.1
- Conforms to MSS SP-70
- Tested According to API 598
- Conforms to ISO 9001:2008

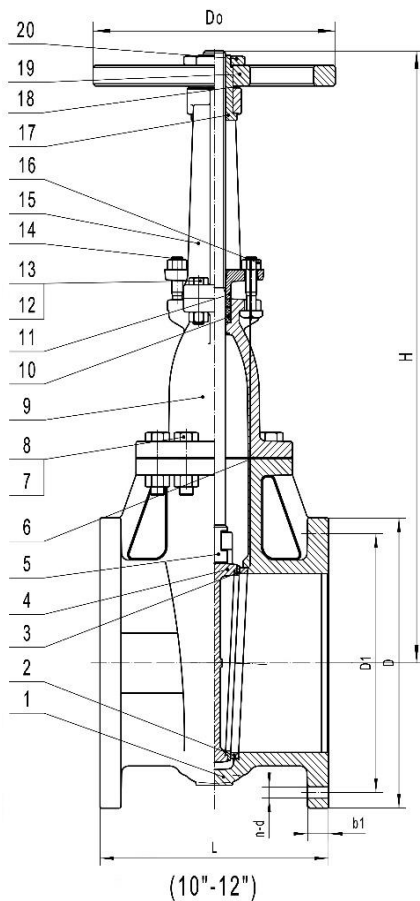

## Materials of Construction

Item	Part	Material	ASTM
1	Body	Cast Iron	A126-B
2	Body Seat Ring	Cast Bronze	B62
3	Wedge Seat Ring	Cast Bronze	B62
4	Wedge	Cast Iron	A126-B
5	Stem	Brass	B16
6	Bonnet Gasket	Graphite	Non-Asbestos
7	Bonnet Bolt	Steel	A307-B
8	Bonnet Nut	Steel	A536-B
9	Bonnet	Cast Iron	A126-B
10	Packing	Graphite	Non-Asbestos
11	Yoke Sleeve	Ductile Iron	A536 60-40-18
12	Gland Bolt	Steel	A307-B
13	Gland Nut	Steel	A536-B
14	Bolt	Steel	A307-B
15	Yoke	Cast Iron	A126-B
16	Nut	Steel	A536-B
17	Stem Nut	Cast Brass	Mn-Brass
18	Handwheel Washer	Brass	B16
19	Handwheel	Cast Iron	A126-B
20	Handwheel Nut	Steel	A563-B

## Dimensions (Inches)

Size	L	D	D1	b1	n-d	Do	H (Open)	Weight (lbs)
10"	13.00	15.98	14.25	1.19	12-1	13.78	44.17	396.83
12"	14.00	19.02	17.01	1.25	12-1	15.75	52.32	592.82

### St. Louis

Midwest & Western U.S.

800-325-7820

Fax: 314-231-1821

### Charlotte

Eastern U.S.

800-438-6946

Fax: 704-331-0646

### Houston

South & Southwest U.S.

888-893-0399

Fax: 281-499-0508

[servicemetal.net](http://servicemetal.net)