

The Best Products, The Best Service...

SERVICE METAL

ONE CALL GETS IT ALL



Welding Laterals – VERSION #1

STANDARD WEIGHT AND EXTRA STRONG

Inches / Pounds

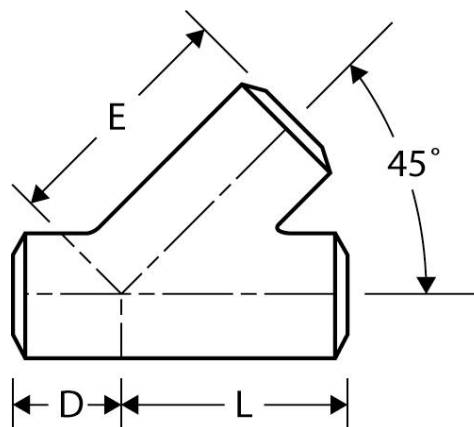

Nominal Pipe Size	Dimensions			Approximate Weight (in Pounds)	
	D	L	E	Standard Wall	Extra Strong
1	1.75	3.5	3.5	1.1	1.4
1 ¼	2	4.25	4.25	1.7	2.3
1 ½	2.5	5	5	2.5	3.4
2	3.25	6	6	4.0	5.6
2 ½	3.5	7	7	7.3	9.7
3	3.75	7.75	7.75	10.2	13.9
3 ½	4	8.38	8.38	13.2	18.1
4	4.5	8.5	8.5	15.9	22.2
5	4.75	11	11	26.8	38.3
6	5.25	12.5	12.5	38	58
8	6.25	15.25	15.25	69	107
10	7	18	18	114	154
12	8	21.5	21.5	166	219
14	10	25	25	218	289
16	12	28.5	28.5	288	381
18	13	32	32	361	479
20	14	35	35	435	580
24	16.25	41.25	41.25	613	817

** The working pressure of any fabricated lateral must be rated at only 40% of the allowable working pressure established for the pipe from which the lateral is being made.*