

Figure 60-OF-U

Class 600 • Outside Screw & Yoke • Flexible Wedge Disc

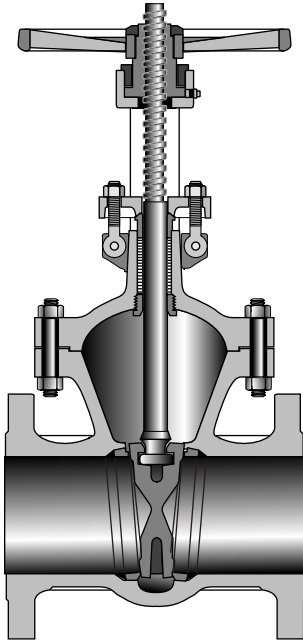

Figure 60-OF-U
Flanged

Size Range:

2 through 16 inches

Pressure Temperature Rating

Carbon Steel
ASTM A216 Grade WCB
1480 psi @ -20°F to 100°F

Materials of Construction

Description	Material
Body	ASTM A216 WCB
Bonnet	ASTM A216 WCB
Seat Rings	ASTM A105 + AWS CoCr-A
Wedge	ASTM A216 WCB + 13% Cr
Stem	ASTM A182 F6a
Packing	Graphite
Bonnet Gasket	Ring Type Joint
Back Seat	ASTM A276 410
Yoke Sleeve	ASTM A439 D2
Retaining Nut	ASTM A216 WCB
Gland	ASTM A276 410
Gland Flange	ASTM A216 WCB
Eye Bolt	ASTM A307 B
Eye Bolt Nuts	ASTM A194 2H
Pins	AISI C1045
Bonnet Studs	ASTM A193 B7
Bonnet Nuts	ASTM A194 2H
Handwheel	Ductile Iron
Handwheel Nut	AISI C1020
I.D. Tags	ASTM A276 304
I.D. Pins	ASTM A276 304
Spacer	ASTM A276 410
Grease Fittings	Carbon Steel

Industry Standards

Steel Valves	ASME B16.34
Face-to-Face/End-to-End	ASME B16.10
Flange Dimensions	ASME B16.5
Basic Design	API 600
Testing	API 598

Dimensions and Weights

Valve Size	Weight (pounds)	Dimensions (inches)		
		A	B (open)	C
2	88	11.5	18.2	9.8
2½	119	13.0	20.3	9.8
3	150	14.0	22.4	11.8
4	282	17.0	27.2	13.8
6	540	22.0	35.8	17.7
8	923	26.0	44.3	19.7
10	1433	31.0	50.5	23.6
12	1962	33.0	58.7	26.8
14	2900	35.0	65.2	34.0
16	3685	39.0	73.7	36.0

