

CAST IRON Y-STRAINERS

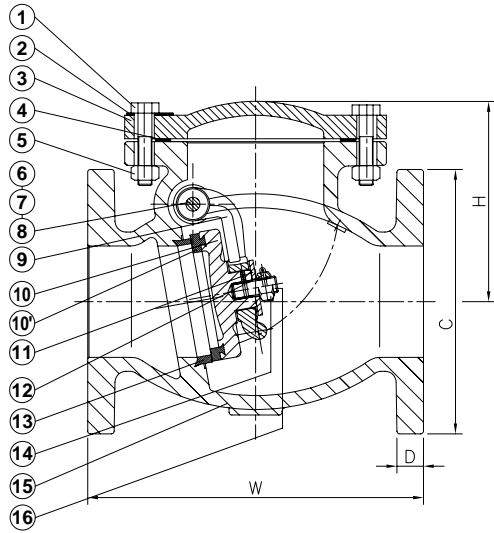

SERIES 570

CLASS 125, FLANGED ENDS (TO ANSI B16.1), BOLTED COVER, FACE-TO-FACE DIMENSIONS TO ANSI B16.10, MSS SP-71 DESIGNED, SIZE:2"-12".



MATERIALS LIST:

NO.	PART	SPECIFICATION
1	BOLT	ASTM A307-B
2	IDENTIFICATION PLATE	ALUMINUM
3	BONNET	ASTM A126 CLASS B
4	BODY GASKET	ASTM A307-B
5	NUT	ASTM A307-B
6	SIDE PLUG	ASTM B16
7	GASKET	NON ASBESTOS
8	HANGER PIN	ASTM B16
9	HANGER	ASTM A536 65-45-12
10	DISC	ASTM A126 CLASS B
10'	DISC RING	ASTM B62
11	WASHER	ASTM A307-B
12	SPLIT PIN	ASTM 420 S42000
13	SEAT RING	ASTM B62
14	DISC NUTS	ASTM A307-B
15	BODY	ASTM A126 CLASS B
16	STUD BOLT	ASTM A307-B



DIMENSIONS:

SIZE		W		H		C		D	
IN	MM	IN	MM	IN	MM	IN	MM	IN	MM
2"	50	8.00	203.2	4.45	113	6	152	0.63	15.9
2-1/2"	65	8.50	215.9	5.24	133	7	178	0.69	17.5
3"	80	9.50	241.3	5.59	142	7.5	190	0.75	19
4"	100	11.50	292.1	6.42	163	9	228.6	0.94	23.8
5"	125	13.00	330.2	7.76	197	10	254	0.94	23.8
6"	150	14.00	355.6	8.35	212	11	279.4	1	25.4
8"	200	19.50	495.3	10.12	257	13.5	343	1.13	28.6
10"	250	24.50	622.3	11.77	299	16	406	1.19	30.2
12"	300	27.50	698.5	13.03	331	19	483	1.25	31.8

DUE TO CONTINUOUS DEVELOPMENT OF OUR PRODUCTS, WE RESERVE THE RIGHT TO MODIFY OUR PRODUCT DESIGN OR CONSTRUCTION WITHOUT PRIOR NOTICE.