

Figure 60-SF-U Class 600 • Bolted Cap

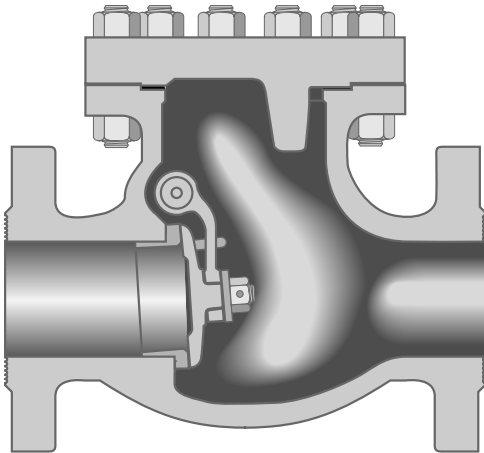

Figure 60-SF-U
Flanged

Size Range:
2 through 12 inches

Pressure Temperature Rating
Carbon Steel
ASTM A216 Grade WCB
1480 psi @ -20°F to 100°F

Materials of Construction

Description	Material
Body	ASTM A216 WCB
Cap	ASTM A216 WCB
Seat Ring	ASTM A105 + AWS CoCr-A
Disc	ASTM A216 WCB + 13% Cr
Hinge	ASTM A216 WCB
Hinge Pin	ASTM A182 F6a
Disc Washer	ASTM A276 410
Cap Screw	ASTM A307 B
Cap Gasket	Ring Type Joint
Cap Studs	ASTM A193 B7
Cap Nuts	ASTM A194 2H
I.D. Tags	ASTM A276 304
I.D. Pins	ASTM A276 304

Industry Standards

Steel Valves	ASME B16.34
Face-to-Face/End-to-End	ASME B16.10
Flange Dimensions	ASME B16.5
Testing	API 598

Dimensions and Weights

Valve Size	Weight (pounds)	Dimensions (inches)	
		A	B
2	82	11.5	7.3
2½	86	13.0	8.0
3	126	14.0	9.1
4	231	17.0	11.9
6	485	22.0	16.8
8	904	26.0	18.9
10	1366	31.0	22.3
12	1807	33.0	26.4

