

# Cast Steel Check Valves



## Figure 30-SF-U Class 300 • Bolted Cap

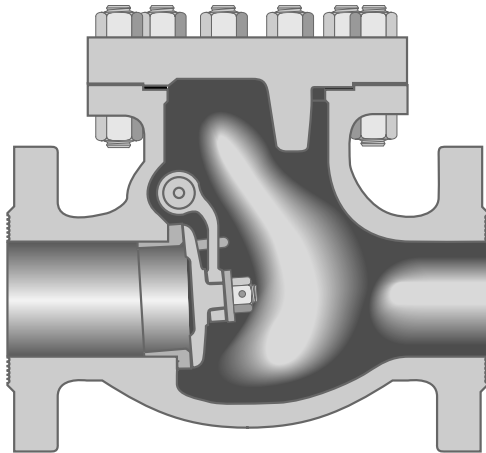

Figure 30-SF-U  
Flanged

**Size Range:**  
2 through 24 inches

**Pressure Temperature Rating**  
Carbon Steel  
ASTM A216 Grade WCB  
740 psi @ -20°F to 100°F

### Materials of Construction

Description	Material
Body	ASTM A216 WCB
Cap	ASTM A216 WCB
Seat Ring	ASTM A105 + AWS CoCr-A
Disc	ASTM A216 WCB + 13% Cr
Hinge	ASTM A216 WCB
Hinge Pin	ASTM A182 F6a
Disc Washer	ASTM A276 410
Cap Screw	ASTM A307 B
Cap Gasket	Soft Steel + Flexible Graphite
Cap Studs	ASTM A193 B7
Cap Nuts	ASTM A194 2H
I.D. Tags	ASTM A276 304
I.D. Pins	ASTM A276 304

### Industry Standards

Steel Valves	ASME B16.34
Face-to-Face/End-to-End	ASME B16.10
Flange Dimensions	ASME B16.5
Testing	API 598

### Dimensions and Weights

Valve Size	Weight (pounds)	Dimensions (inches)	
		A	B
2	44	10.5	6.9
2½	66	11.5	7.3
3	86	12.5	8.4
4	148	14.0	9.7
5	287	15.8	10.6
6	276	17.5	12.2
8	463	21.0	16.7
10	650	24.5	18.9
12	857	28.0	21.7
14	1499	33.0	25.8
16	1840	34.0	28.1
18	2193	38.5	29.9
20	2909	40.0	31.7
24	4188	53.0	35.6

