

The Best Products, The Best Service...

SERVICE METAL

ONE CALL GETS IT ALL



Reducing Companion Flanges

125# Cast Iron
Inches / Pounds

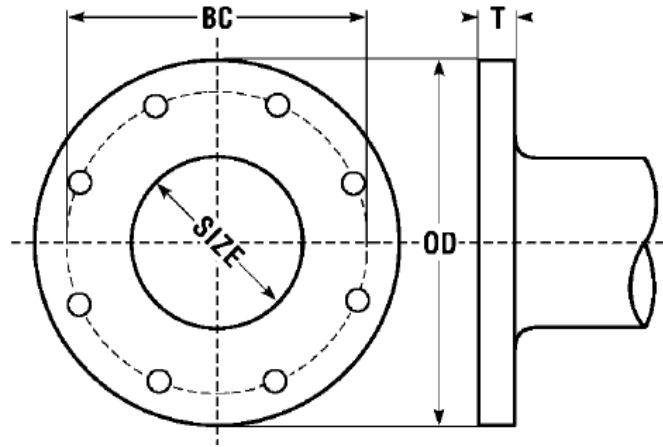

Size	Diameter Holes	# of Holes	Outside Diameter (OD)	Bolt Circle (BC)	Thickness (T)	Flange Weights (in Pounds)
1 x 4-5/8	0.62	4	4.62	3.50	0.50	3
1 x 5	0.62	4	5.00	3.88	0.56	3
1 x 6	0.75	4	6.00	4.75	0.62	5
1 x 7	0.75	4	7.00	5.50	0.69	7
1 ¼ x 6	0.75	4	6.00	6.00	0.75	4
1 ½ x 6	0.75	4	6.00	6.00	0.75	4
1 ½ x 7	0.75	4	7.00	5.50	0.69	6
1 ½ x 7 ½	0.75	4	7.50	6.00	0.75	9
1 ½ x 9	0.75	8	9.00	7.50	0.94	15
1 ½ x 10	0.88	8	10.00	8.50	0.94	19
1 ½ x 11	0.88	8	11.00	9.50	1.00	24
2 x 7	0.75	4	7.00	5.50	0.69	7
2 x 7 ½	0.75	4	7.50	6.00	0.75	8
2 x 8 ½	0.75	8	8.50	7.00	0.81	10
2 x 9	0.75	8	9.00	7.50	0.94	16
2 x 10	0.88	8	10.00	8.50	0.94	17
2 x 11	0.88	8	11.00	9.50	1.00	23
2 x 13 ½	0.88	8	13.50	11.75	1.12	44
2 x 16	1.00	12	16.00	14.25	1.19	60
2 x 19	1.00	12	19.00	17.00	1.25	87
2 ½ x 7 ½	0.75	4	7.50	6.00	0.75	8
2 ½ x 9	0.75	8	9.00	7.50	0.94	13
2 ½ x 10	0.88	8	10.00	8.50	0.94	18
2 ½ x 11	0.88	8	11.00	9.50	1.00	22
2 ½ x 13 ½	0.88	8	13.50	11.75	1.12	40

The Best Products, The Best Service...

SERVICE METAL

ONE CALL GETS IT ALL



Size	Diameter Holes	# of Holes	Outside Diameter (OD)	Bolt Circle (BC)	Thickness (T)	Flange Weights (in Pounds)
3 x 9	0.75	8	9.00	7.50	0.94	13
3 x 10	0.88	8	10.00	8.50	0.94	17
3 x 11	0.88	8	11.00	9.50	1.00	21
3 x 13 ½	0.88	8	13.50	11.75	1.12	37
3 ½ x 11	0.88	8	11.00	9.50	1.00	22
3 ½ x 13 ½	0.88	8	13.50	11.75	1.12	39
4 x 10	0.88	8	10.00	8.50	0.94	14
4 x 11	0.88	8	11.00	9.50	1.00	21
4 x 13 ½	0.88	8	13.50	11.75	1.12	35
5 x 11	0.88	8	11.00	9.50	1.00	20
5 x 13 ½	0.88	8	13.50	11.75	1.12	32
6 x 13 ½	0.88	8	13.50	11.75	1.12	30
6 x 16	1.00	12	16.00	14.25	1.19	55
8 x 16	1.00	12	16.00	14.25	1.19	45
8 x 19	1.00	12	19.00	17.00	1.25	76
10 x 19	1.00	12	19.00	17.00	1.25	68

****Flange Dimensions Listed Above Apply to Both 125# Cast Iron and 150# Ductile Iron***

****Threads for Companion Flanges Conform to ANSI/ASME B1.20.1 NPT***

****All Flanges are Asphalt Coated as Standard, Hot Dip Galvanizing Available***