

The Best Products, The Best Service...

SERVICE METAL

ONE CALL GETS IT ALL



Companion Flanges 125# Cast Iron Inches / Pounds

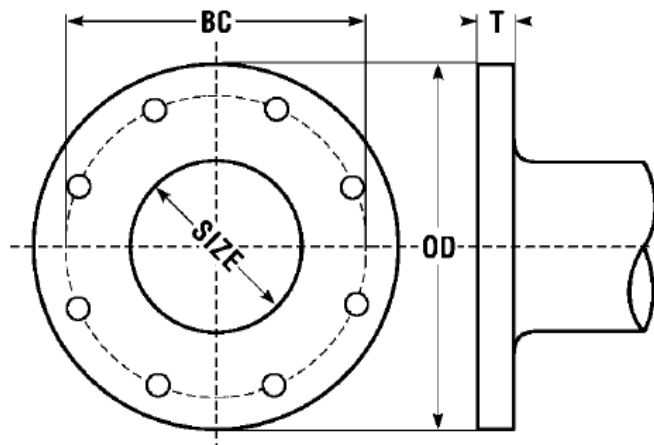

Size	Diameter Holes	# of Holes	Outside Diameter (OD)	Bolt Circle (BC)	Thickness (T)	Companion Flanges Weight (in Pounds)
1/2	0.62	4	3.50	2.38		1
3/4	0.62	4	3.89	2.75		1
1	0.62	4	4.25	3.12	0.44	1
1 1/4	0.62	4	4.62	3.50	0.50	2
1 1/2	0.62	4	5.00	3.88	0.56	3
2	0.75	4	6.00	4.75	0.62	4
2 1/2	0.75	4	7.00	5.50	0.69	6
3	0.75	4	7.50	6.00	0.75	8
4	0.75	8	9.00	7.50	0.94	12
5	0.88	8	10.00	8.50	0.94	14
6	0.88	8	11.00	9.50	1.00	16
8	0.88	8	13.50	11.75	1.12	28
10	1.00	12	16.00	14.25	1.19	38
12	1.00	12	19.00	17.00	1.25	55
16	1.12	16	23.50	21.25	1.44	100

**Flange Dimensions Listed Above Apply to Both 125# Cast Iron and 150# Ductile Iron*

**Threads for Companion Flanges Conform to ANSI/ASME B1.20.1 NPT*

**All Flanges are Asphalt Coated as Standard, Hot Dip Galvanizing Available*