

The Best Products, The Best Service...

SERVICE METAL

ONE CALL GETS IT ALL



Blind Flanges 125# Cast Iron Inches / Pounds

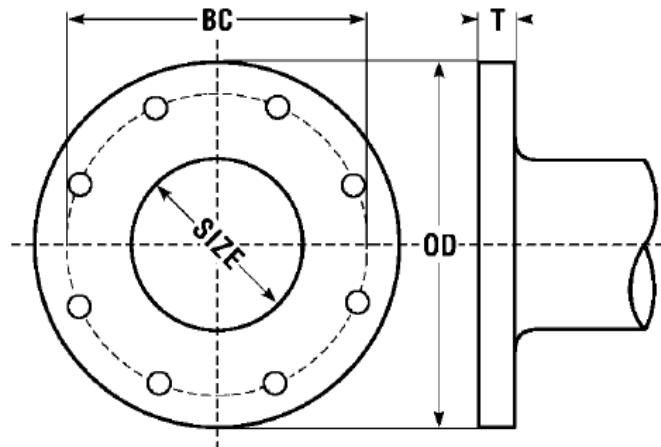

Size	Diameter Holes	# of Holes	Outside Diameter (OD)	Bolt Circle (BC)	Thickness (T)	Blind Flanges Weight (in Pounds)
1	0.62	4	4.25	3.12	0.44	2
1 ¼	0.62	4	4.62	3.50	0.50	2
1 ½	0.62	4	5.00	3.88	0.56	4
2	0.75	4	6.00	4.75	0.62	5
2 ½	0.75	4	7.00	5.50	0.69	7
3	0.75	4	7.50	6.00	0.75	9
3 ½	0.75	8	8.50	7.00	0.81	14
4	0.75	8	9.00	7.50	0.94	15
5	0.88	8	10.00	8.50	0.94	18
6	0.88	8	11.00	9.50	1.00	23
8	0.88	8	13.50	11.75	1.12	37
10	1.00	12	16.00	14.25	1.19	59
12	1.00	12	19.00	17.00	1.25	89
14	1.12	12	21.00	18.75	1.38	101
16	1.12	16	23.50	21.25	1.44	152
18	1.25	16	25.00	22.75	1.56	172
20	1.25	20	27.50	25.00	1.69	226
24	1.38	20	32.00	29.50	1.88	355
30	1.38	28	38.75	36.00	2.12	

**Flange Dimensions Listed Above Apply to Both 125# Cast Iron and 150# Ductile Iron*

**All Flanges are Asphalt Coated as Standard, Hot Dip Galvanizing Available*